

LAMINOVA Heat Exchanger Systems

Intercooler

Laminova heat exchangers are especially designed for intercoolers in turbo and super-charged petrol and diesel engines. The heat exchangers are compact, easy to install and more efficient than conventional coolers.

Laminova heat exchanger systems have a unique designed core for intercooler applications. The air-to-liquid system gives increased efficiency compared to an air-to-air system. With the air-to-liquid system you will get cold air right from the start.

High performance

The high performance, compared to that of the common plate style intercoolers, is a result of the extremely large surface area and the unique flow pattern. Laminova core design gives an extremely low pressure drop on the charged air side.

Compact design

Laminova coolers are small, compact and circular. The compact core design makes it easy to install in the inlet manifold. The heat exchanger core are patented.

Better torque, response and performance

With intercooler cores installed, you achieve better torque, response and performance compared to those of conventional coolers. The coolers effectively increase engine efficiency and decrease fuel consumption.

Environmental advantages

The intercooler reduces hazardous emissions of nitrogen, e.g. The engine temperature becomes more even due to improved air distribution balance.

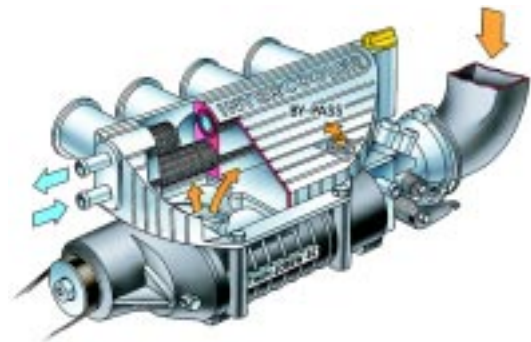

Put all of these benefits together:

- Superior cooling performance.
- Extremely low pressure drop.
- Ideal to integrate in the inlet manifold.
- Increased response due to short flow length in the system.
- Robust design. One-piece aluminium extrusion.
- No soldering or braising - soft mounting with O-rings.
- Reduced noise and pulsation. Improved air-distribution balance.
- Can be combined with the air conditioning system.



The core can be delivered as a separate component, ready for installation.

We have cooler ideas!

Installation

Best result is achieved if the heat exchanger is installed in the inlet manifold. This improves the response compared to that of traditional air-to-air intercoolers due to shorter flow length. The Laminova intercooler reduces the noise level and pulsation.

Special core for charged engines

We have a special core for air flow in charged engines. This core has longer and higher fins and fewer break-up zones (more surface) than the traditional core for liquid applications. Normally, a package of 2-4 cores is needed to meet specifications. Cores used are $\varnothing 39.5$ and $\varnothing 45$ mm.

Separate cooling circuit

The air-to-liquid intercooler system needs a separate cooling circuit with a circulation pump and a separate radiator. Laminova also supplies intercooler housings for use in racing/aftermarket applications and as prototypes for test and evaluation.

Usage with air conditioning systems

The Laminova intercooler can be combined with the air conditioning system for even better efficiency. Please contact Laminova for further information.

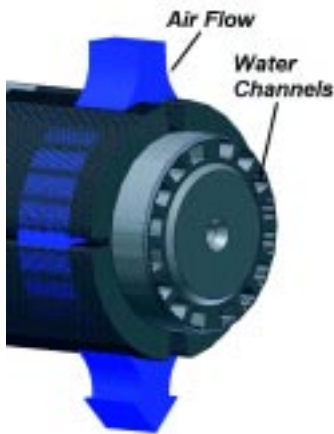

Air flow over the core.

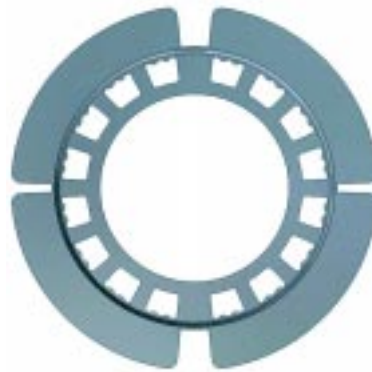

Special core for intercooler.

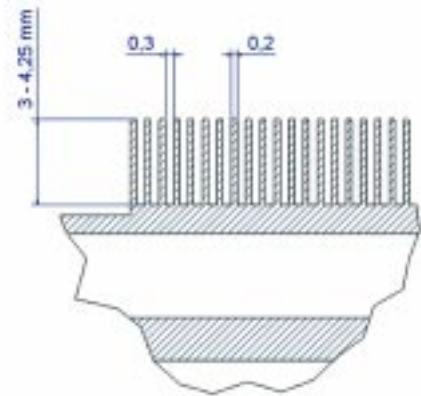

Cross section of a core showing height of fins, distances between them and their thickness in mm.

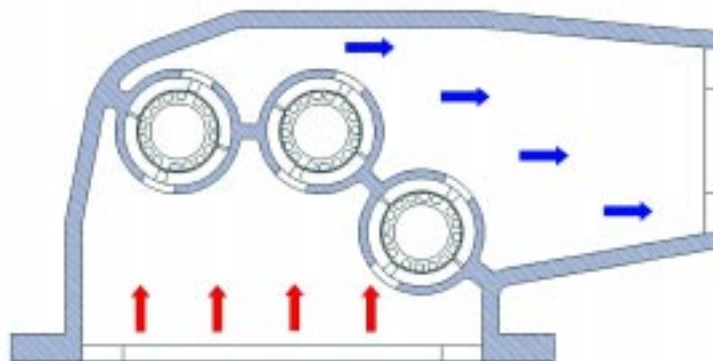

Example of air flow in an inlet manifold.

Art no 02-08-IC1